



NEW HOLLAND T9

T9.435 | T9.480 | T9.530 | T9.565 | T9.600 | T9.645 | T9.700



NEW T9. NON-STOP FARMING.

At New Holland we have put all our tractor building experience into making the new T9 tractor series more comfortable and even easier to drive. We have not neglected your core demands either. High capacity axles, advanced transmission control and ultra-efficient power units are housed in a chassis size to match your business needs. Just take a look at what T9 series tractors have to offer.



MORE POWER AND PRODUCTIVITY

T9 tractor engines utilize the award-winning ECOBlue™ HI-eSCR technology for Tier 4B compliance. This technology has increased all rated and maximum powers, meaning your T9 packs even more of a punch. Using cutting-edge and multi-patented High Efficiency Selective Catalytic Reduction (HI-eSCR) technology, the Cursor 9 and 13 powerplants breathe clean, fresh air for optimal combustion and enjoy a significant performance advantage. With Engine Power Management (EPM), up to 71 additional horsepower is available in demanding hydraulic, PTO and transport applications for optimum productivity. With EPM, the T9.700 with 628 rated horsepower can develop up to 692 horsepower!



ABSOLUTE DRIVING PLEASURE

New Holland puts the operator right at the heart of the tractor. An all new luxury seat features weight compensated damping and integrated ventilation to further enhance the operating experience. Easy-to-use controls are matched to outstanding all-round visibility. Transmission shifting has been made even slicker, and when combined with four-point Comfort Ride™ cab suspension, you'll enjoy the smoothest ride around.





MAXIMUM VERSATILITY

New Holland T9 tractors come in two chassis sizes. Four European Homologated Standard-frame (36-inch) T9 models are row-crop ready and deliver maximum horsepower of 435 up to 557. To enhance versatility a new wide frame model has been launched, so you now have a wider power range to choose from in the three-model 44-inch range, delivering maximum horsepower of between 602 - 692, these tractors are perfect for broad-acre work. The T9.530, T9.600 and T9.645—are available as scraper tractors equipped expressly for moving tons of earth day after day.



LOWER OPERATING COSTS

A sound investment delivers the best returns. Operating costs for T9 tractors with ECOBlue™ HI-eSCR maintain the low operating costs you have come to expect of your T9, and maintain the 10% fuel reduction when compared to previous T9000 Tier 3 models. Want more? Well, PTO speed is now achieved at a mere 1800 rpm. Saving you fuel and reducing in-cab noise.

EXACTLY WHAT IT SAYS ON THE BONNET

T9 tractors offer improved performance thanks to the Tier 4B ECOBlue™ HI-eSCR advantage, and these productivity enhancing characteristics are immediately obvious to all users. How? Quite simply, it is on the bonnet. The first two digits 'T9' refer to the tractor's category and the following three, for example '700', refer to the maximum Engine Power Management horsepower. What does that mean to you? You can buy your T9 safe in the knowledge that it will be able to cope with even the most demanding applications. New Holland for ultimate productivity peace of mind.

Max power with EPM [hp(CV)]

T9.435	435
T9.480	469
T9.530	525
T9.565	557
T9.600	613
T9.645	647
T9.700	692



These are maximum engine powers that the T9 range can deliver for mobile PTO and high speed haulage tasks.

Max power [hp(CV)]

T9.435	411
T9.480	469
T9.530	525
T9.565	557
T9.600	613
T9.645	647
T9.700	692



For draft work, such as tillage equipment, the T9 will deliver these maximum power values.

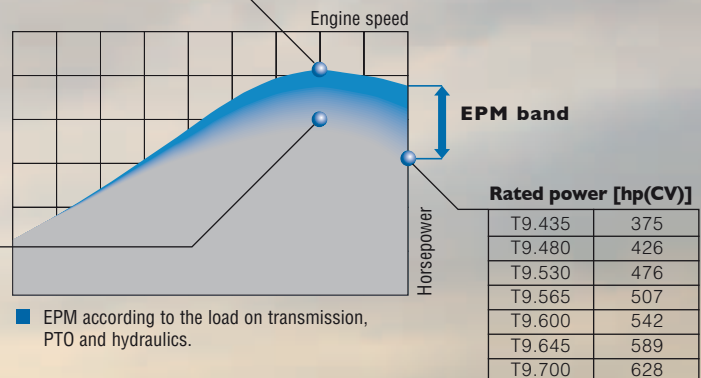

Rated powers are a useful reference but are usually surpassed by the max power figures during work, with or without EPM active.



A GREAT VIEW FROM THE MOST COMFORTABLE AND QUIETEST CAB IN THE BUSINESS

CAB THAT WORKS WITH YOU, DAY IN, DAY OUT

Step into the spacious cab through the frameless door. Settle into the seat and rest your arm on the SideWinder™ II armrest. Work the buttons on the CommandGrip™ handle and remote valve paddles. Swap through the menus on the IntelliView™ IV touchscreen monitor. Fire up the engine and feel its smooth quiet power. Welcome to New Holland.

THE MOST COMFORTABLE SEAT ON THE FARM

Comfort is guaranteed thanks to the deluxe air-suspension seat that comes as standard equipment. For operators who spend extended hours in the tractor, the enhanced comfort of the ventilated semi-active Auto Comfort™ seat is worth considering. This range topping seat automatically calibrates damping, using a network of sensors, depending on the operator's actual weight, for the smoothest ride ever. The seat also features advanced ventilation technology, which warms the body on cold days and efficiently whisks away perspiration for ultimate comfort in all weathers. When combined with Comfort Ride™ cab suspension, it's the smoothest ride ever. For an added touch of luxury, select the full leather option.



SETTLE IN AND ENJOY THE RIDE

New Holland Comfort Ride™ cab suspension, offered on all T9 series tractors, is revolutionary. All four corners of the cab are suspended on spring and damper units with a sophisticated anti-sway system to ensure you get a smooth and stable ride. Captive pin mounts provide full roll over protection.



AT 76dB(A), A T9 CAB IS WHISPER QUIET



40° SWIVEL ANGLE

SWIVEL FOR ULTIMATE COMFORT

Operators who extensively use large rear equipment will be able to work in absolute comfort, thanks to the seat's 40° swivel angle. Moreover, the SideWinder™ II armrest moves with the seat, so the controls are always where you need them, no need for stretching or fumbling. Comfortable rear visibility. Check.



FROM DUSK TO DAWN

Cab roof, engine hood and fender worklights are easily controlled from a dedicated switch panel. The operator can set up the lights to match a broad range of applications for safer, more productive operation.

SET YOUR PERSONAL WORKING ENVIRONMENT

Set your preferred in-cab working temperature. The automatic climate control system will maintain this setting, adjusting to suit ambient conditions. Pull down cab blinds to keep out the sun.

HIGH QUALITY AUDIO

The integrated radio allows the operator to play their own MP3 music recordings as well as receive crystal clear radio signals. Full access to weather radio channels is also available.

SIDEWINDER II. DESIGNED AROUND YOU.

As modern tractors offer increasingly sophisticated features there is a risk that they become more difficult to understand and operate. At New Holland we listened to our customers and developed the SideWinder™ II armrest to make everything simpler. All key controls are accessed from the armrest. Throttle, transmission and hydraulics. Everything you need to control is quickly and easily accessible. More advanced features can also be quickly accessed. Get in. Settle down. Job done.

INTELLIVIEW™ TOUCHSCREEN MONITOR

All the information you need at a glance. With the standard 26.4cm wide IntelliView™ IV monitor, you'll enjoy fingertip adjustment of all key settings and full compatibility with the New Holland IntelliSteer® guidance system.



The soft-touch buttons feature backlight technology to make selecting controls in the dark even easier.

- Headland Turn Sequencing (HTS). Press to record, store and activate automated headland turn.
- Fingertip control for up to two remote valves.
- Rear linkage raise lower.
- Optional IntelliSteer® auto-guidance, automated steering engagement.
- Forward reverse shuttle switch.
- Ground Speed Management, GSM. Transmission and engine work together to optimise performance.
- Change transmission ratio up and down.
- Precisely modify the target GSM speed.
- Electronic SideWinder™ II adjustment. Move the armrest to the position that suits you.





As awarded by The Chicago Athenaeum: Museum of Architecture and Design.



EASY ACCESS TO ADVANCED FEATURES

Push the symbol. Activate the feature. The Integrated Control Panel, ICP, makes it simple to access advanced operating features. No need to scroll through menus to set up Terralock traction management, Headland Turn Sequencing (HTS), Auto PTO or ESM Engine Speed Management.



- Personalized positioning of the hydraulic joystick and rear linkage mouse available as a factory-fit option. Also two additional paddles control hydraulic remote valves 5 and 6, and can be installed instead of the hydraulic joystick.
- Automatic engine braking activation.
- Throttle up to your desired engine speed, select Engine Speed Management, and the speed is fixed.
- Press the Headland Turn Sequencing (HTS) button to record and replay the functions you use most frequently.
- Engage the rear and front differential locks, true traction.
- Three point hitch levelling and top link extension at the touch of a button.
- Multifunction joystick. The joystick can be set to operate the front blade or remote valves.
- Electronic remotes. Easy to reach paddles provide fingertip hydraulic operation. Flow and timing can be simply adjusted through the IntelliView™ touch screen.
- EDC mouse. Lift heavy mounted implements with absolute precision.
- Full access to further advanced controls under the padded armrest.

NEW HOLLAND GUIDANCE SYSTEMS TO MATCH YOUR NEEDS

ALL WIRED UP READY FOR YOUR CHOSEN GUIDANCE SYSTEM

T9 tractors can be specified with a fully integrated New Holland designed and developed IntelliSteer® Automatic Steering System. Matching DGPS or RTK Technology to fully integrated control, IntelliSteer® helps ensure parallel pass to pass accuracy of up to 1–2cm*. IntelliSteer® is ideal for precision work in even the most demanding situations. It is designed to dramatically improve operator performance and comfort. All this and more at the touch of a button.

* Using RTK correction signal.

FULLY INTEGRATED INTELLISTEER® GUIDANCE

Guidance system choice will relate to the intended applications and the need to integrate with existing systems. With T9 series tractors, all IntelliSteer® options operate via factory installed systems that facilitate installation and upgrades. This enables the selected package to be modified and upgraded simply and more economically.

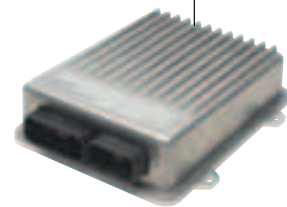
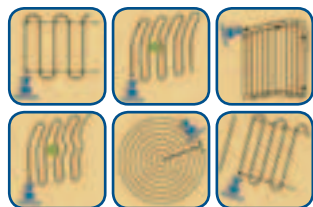

INTELLIVIEW – VISIBLE INTELLIGENCE

The standard IntelliView™ IV monitor can be used to set up the optional New Holland auto guidance systems, and include a visual interface that can be employed when operating the IntelliSteer® system. The IntelliView™ monitors have a touchscreen display which allows the programming of a variety of guidance paths, from straight A-B runs to the most complex adaptive curves. You can also personalize your settings simply and easily and even transfer information from your tractor, direct to your PLM® Software package. Moreover, an optional dual screen solution has been developed, which enables operators to view IntelliSteer® auto guidance run screens and coverage maps as well as vehicle controls simultaneously.

INTEGRATED CONTROL SYSTEMS

The New Holland IntelliSteer® System uses built in T3 terrain compensated correction signals (roll, pitch, yaw) to keep the Navigation Controller II informed of the tractor's orientation. Also integrated into the hydraulic system is a control valve which converts the signals from the Navigation Controller II into hydraulic movements of the steering system.

TELEMATICS: MANAGE YOUR MACHINE FROM THE COMFORT OF YOUR OFFICE

PLM® Connect enables you to connect to your T9 from the comfort of your office through the utilization of the mobile network. You can stay in touch with your machines at all times, and you can even send and receive real-time information that saves time and enhances productivity. The entry-level PLM® Connect Essential package offers the most frequently used features or upgrade to the PLM® Connect Professional package for full machine monitoring and control. In short, PLM® Connect will help you to reduce your fuel bills and improve fleet management and security in one simple package.

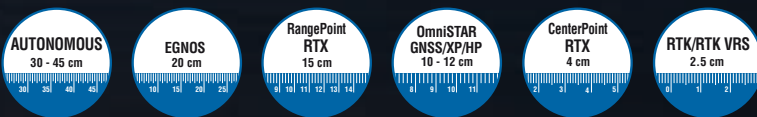

LEVELS OF ACCURACY AND REPEATABILITY

New Holland offer five levels of accuracy. This enables you to select the right IntelliSteer® system to match your needs and budget. When using RTK correction with IntelliSteer® it is possible to deliver year on year repeatability.

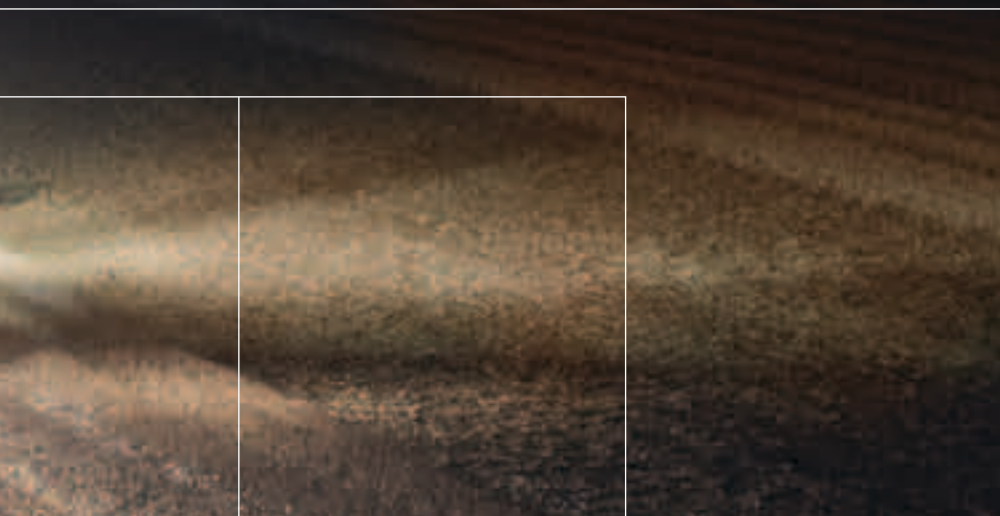

INTELLISTEER®. ON AND OFF SIMPLICITY.

The CommandGrip™ handle incorporates a single button that is used to activate the IntelliSteer® system. New Holland makes advanced technology accessible.

FULL LASER LEVELLING INTERFACE

The electro-hydraulic system of T9 scraper tractors is 'plug and play' compatible with a wide range of third-party laser controlled levelling systems.

NH 372 RECEIVERS

The NH 372 receiver is capable of working with EGNOS, OmniSTAR, GLONASS or RTK correction signals. For RTK applications an integrated radio receiver is located inside the main receiver.

RTK BASE STATION

An RTK base station can be used to broadcast a correction signal to achieve a pass to pass accuracy of 1–2cm.

THE POWER AND EFFICIENCY YOU'VE COME TO EXPECT FROM NEW HOLLAND

Your T9 tractor is powered by an ECOBlue™ HI-eSCR (High Efficiency Selective Catalytic Reduction) Cursor 9 or 13 engine, which has been developed by New Holland's sister company FPT Industrial. These engines, which comply with the even more stringent Tier 4B emissions norms, offer you four key benefits:

- **Performance:** more power, torque, torque back-up and engine power management whilst maintaining outstanding transient response.
- **Efficient operation:** the fluid consumption (diesel plus AdBlue) will be the same or better than your Tier 4A T9. You will also benefit from reduced life-long operating costs.
- **Simplicity:** the simpler engine installation ensures a higher power potential and the reduced cooling system delivers more efficient operation.
- **Consistency:** there will be no change in vehicle operation.



POWERED BY FPT INDUSTRIAL

New Holland is not going it alone when it comes to Tier 4 technology. They can draw on the experience of their in-house engine development group: FPT Industrial.

Pioneers: Fiat invented Common Rail technology in the 1980s and brought it to the masses in 1997 on the Alfa Romeo 156. They were the very first to introduce it on agricultural machines on the TS-A tractor. Pioneering. Always.

Cleaner: For the fourth consecutive year, CNH Industrial has topped the Dow Jones Sustainability World and Europe indexes for the Industrial Engineering sector. Cleaner. Everywhere.

Proven: FPT Industrial has pioneered SCR technology since 1995 and has already produced over 450,000 SCR engines during the last eight years for the agricultural, construction and trucking industry. The award-winning HI-eSCR solution has been extensively tested and clinched the European Truck of Year 2013 award for the Iveco Stralis Hi-Way heavy duty on-road truck Reliability. Confirmed.

DESIGNED AND BUILT BY FPT INDUSTRIAL

Purposely developed for agriculture, the two-stage turbocharged engines of the T9.600, T9.645 and T9.700 tractors are all part of the proven New Holland efficiency package. The aim? To deliver improved power and sustained output in varying load conditions. So you get all power you need from less fuel. All models meet stringent Tier 4B emission standards.



Sustainable Efficient Technology

ECOBBLUE™ HI-eSCR EXPLAINED

An evolution of the existing ECOBlue™ SCR system, you will benefit from the highest NOx conversion efficiency in the industry. This multi-patented system uses a new Engine Control Unit, which not only manages the engine, but also the HI-eSCR after treatment system by controlling the supply and dosing modules. Using a dedicated closed loop system, it continuously monitors the NOx levels in the exhaust gases, ensuring that during every cycle the precise amount of DEF is injected to achieve NOx conversion of over 95%, all while guaranteeing low fluid consumption.

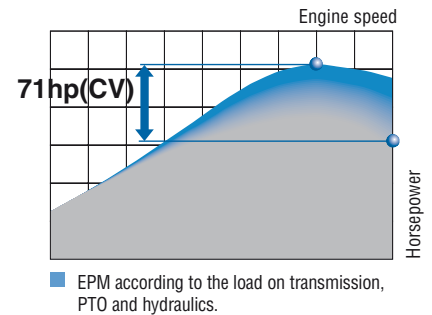
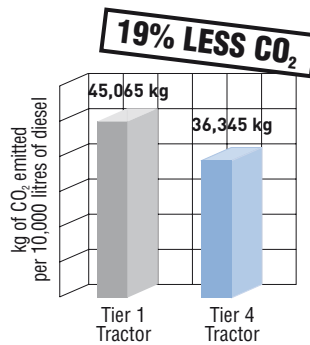
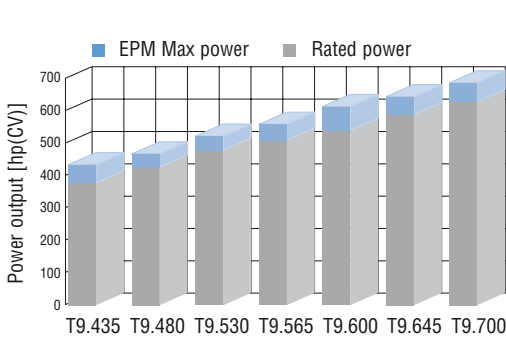
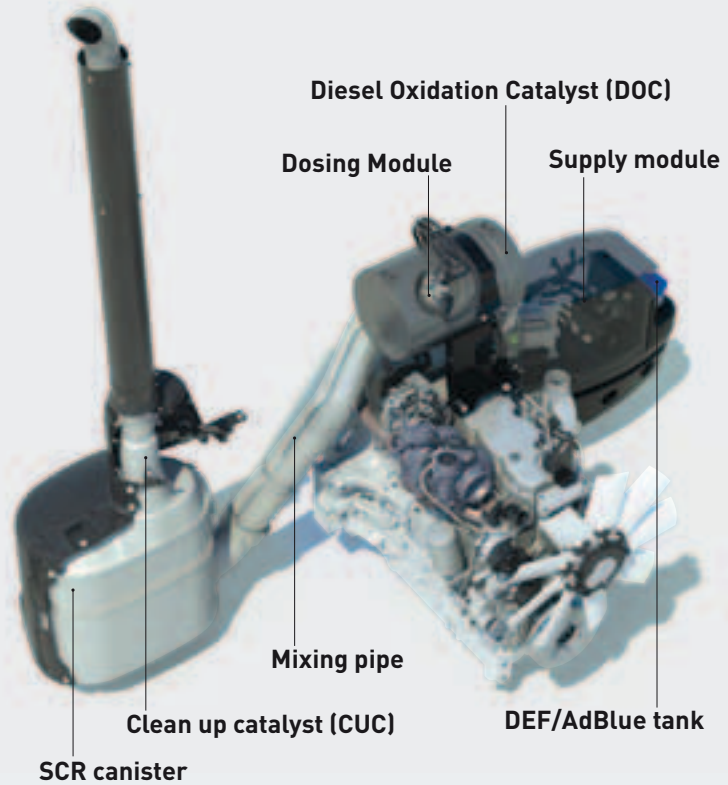

ECOBBLUE™ HI-eSCR: YOUR POWER GUARANTEE

ECOBBlue™ HI-eSCR technology has increased the power and already exceptional productivity of your T9, independent of fuel quality, sulphur levels and without the need for costly diesel additives. More power from less fuel with clean emissions. Moreover, an additional wide frame model producing a maximum of 642hp(CV) has further enhanced your choice to ensure you have exactly the right tractor for your operation.

SAVE FUEL TO REDUCE YOUR CARBON FOOTPRINT

Emissions released from burning diesel are a significant contributor to a farm's overall carbon footprint. ECOBlue™ HI-eSCR technology for Tier 4B compliance reduces NOx emissions and maintains the T9 Series' impressive fuel efficiency, bringing about a substantial cut in your farm's carbon emissions. Visit www.carbonid.newholland.com to find out just how much carbon you could save!

ENGINE POWER MANAGEMENT

Engine Power Management is a renowned New Holland tractor feature. In short, the engine develops more power and torque according to the load on the transmission, hydraulics and PTO. On a T9.600 tractor, EPM will deliver up to 71hp(CV) extra but only when it is needed to maintain performance.

PROVEN DESIGN, MODERN CONTROL

THE FULL POWERSHIFT, TOUGHENED UP

Now with added strength and improved control, the Ultra Command™ full powershift transmissions developed for T9 tractors is something special. First, it benefits from a new control system using the CommandGrip™ handle. This provides finger tip access to ‘manual’ push button shifts and automated Ground Speed Management. A Hi-Lo dual power is fitted to gear 16. This enables the maximum transport speed to be increased from 31 to 37kph.

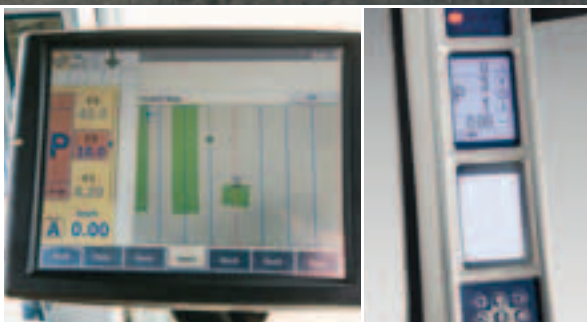
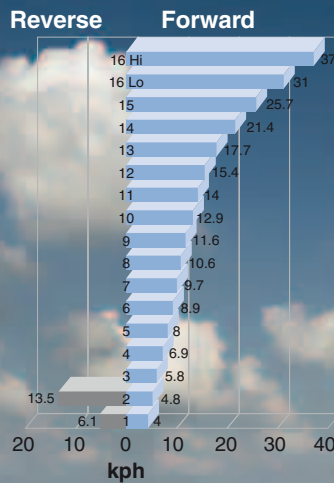

INTELLIVIEW - GEAR AND SPEED AT A GLANCE

The IntelliView™ display offers easy toggling between menus to display information including the exact engine speed and the selected transmission ratio. This information is duplicated by the “A” pillar display, so you always have key operating data within view.



GSM. INTELLIGENT AUTOMATION.

New Holland Ground Speed Management, GSM, is more than just an automated transmission shift system. With CVT-like functionality, it uses a combination of data relating to engine load, forward speed and operator setting, to manage both engine and transmission speeds to optimise performance and economy. Simple to set up and extremely efficient, GSM is well proven and dependable.

FIXED FORWARD SPEED? GSM TAKES CARE OF IT.

When load conditions change in the field, GSM will automatically maintain a fixed forward speed. The operator first sets the desired working speed and then selects the GSM function. The automated system will then match engine and transmission speeds to maintain this fixed forward speed, to deliver the perfect balance between maintaining productivity without compromising economy.

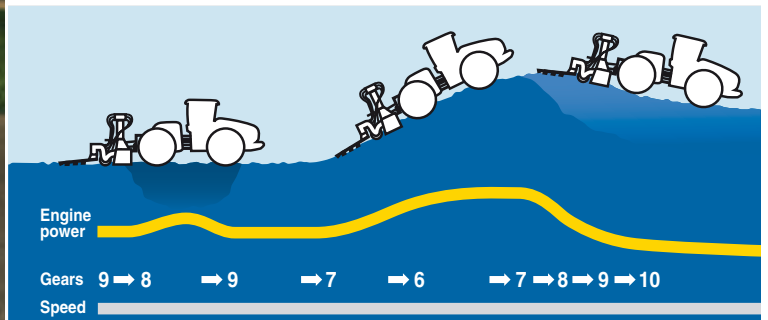

FULL COMMAND IN TRANSPORT

During road transport, GSM will automatically shift the transmission according to load and throttle settings. With heavy loads, GSM will downshift to assist with engine braking on steep inclines.

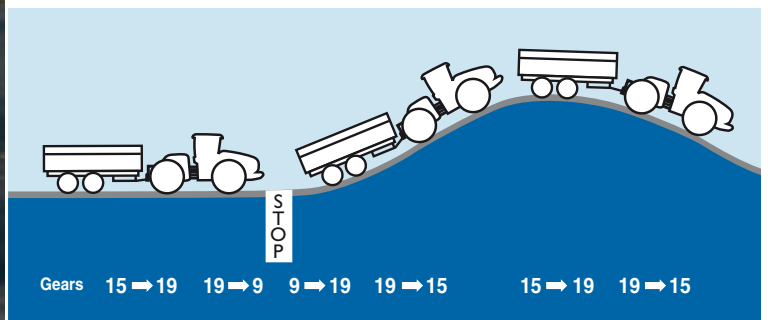

QUICK AND SMOOTH: EASY SHUTTLING

Shuttle speed has been improved to deliver faster direction changes, this is ideal when working on silage clamps, to improve operating efficiency. When shuttling between forward and reverse, the transmission always defaults to the first reverse gear. On T9 scraper models, you can select either the first or second reverse gear. To reduce shock loads on the transmission, the shuttle clutch pack is fully modulated for a smooth change in travel direction.



WE HAVE THE TRACTOR THAT ANSWERS YOUR NEEDS

Some of you told us you wanted a row-crop-ready articulated tractor with a tapered hood for better forward visibility... with inboard planetary drive axles for narrow wheel width settings. Take a look at the standard-frame T9.435, T9.480, T9.530 or T9.565 with rated powers of 380 to 564 horsepower. For broad-acre work, you asked, we listened, and we introduced a third model in the wide-frame range. You can now choose between the T9.600, T9.645 or the mighty T9.700. They deliver even greater performance, producing rated power of between 548 - 635 horsepower and are packaged in a beautifully balanced chassis to deliver more power to the ground for improved productivity.

STANDARD FRAME
900/60R42 super singles

STANDARD FRAME
710/70R42 duals

WIDE FRAME
800/70R38 duals

WIDE FRAME
520/85R46 triples

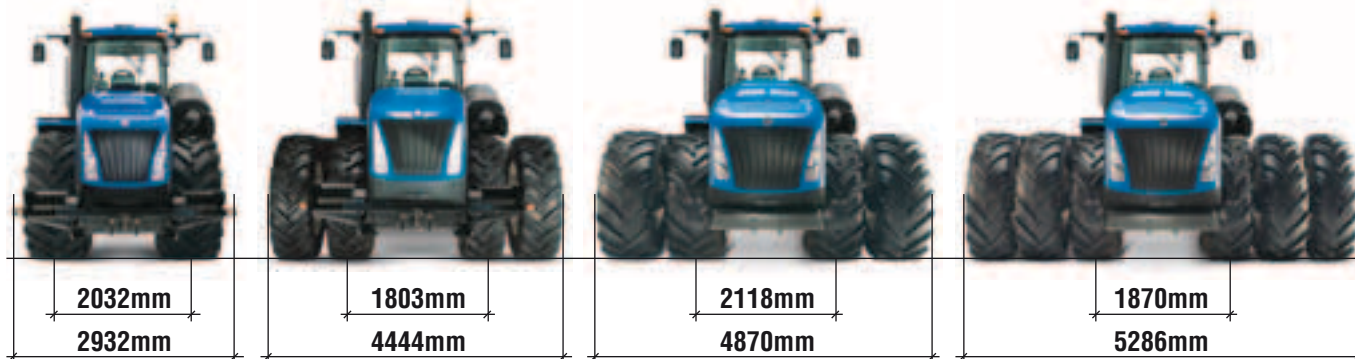

EUROPEAN HOMOLOGATED

TERRALOCK™ TRACTION MANAGEMENT

Where specified, Terralock will automatically manage the engagement and the locking of the front and rear differentials. Of equal importance, the system takes care of disengaged during high working speeds and when the brake pedal is applied.



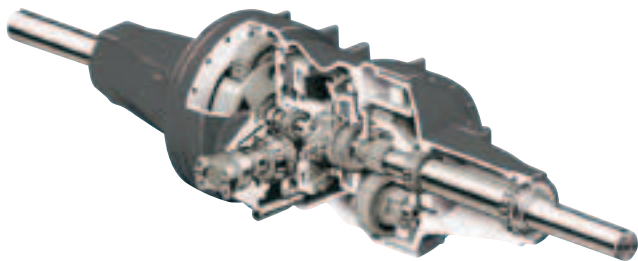

AXLES BUILT FOR THE JOB

Regardless of frame size, T9 axles have been engineered and built to stand up to even the most demanding conditions. These tough axles handle high torque loads with ease, and also offer absolute operator comfort. How? They feature planetary input gears for the ultimate in quiet operation.



THE RIGHT WHEELS AND TYRES FOR YOUR APPLICATION

All models can be operated with single, dual and triple configurations. Standard frame T9 tractors can now be fitted with 900/60R42 Super Single through to narrow but extra tall dual 480/95R50 tyres for improved ground contact.



MORE STOPPING POWER

T9 tractors are fitted with a completely new braking system. Both the transport and park brakes are more powerful with a trailer braking circuit included as standard. Automatic engine braking is activated during transport. This uses the engine to slow the tractor when the throttle is fully released.

ROBUST DESIGN MEETS PERFECT BALANCE

New Holland T9 tractors use an exceptionally robust articulated Tri-Point chassis. Engineered to reduce maintenance and provide exceptional strength, the Tri-Point system ensures a well balanced weight transfer between the front and rear axles. In both drawbar and three-point linkage applications, significantly less ballast is required. This can assist owners seeking to reduce equipment weights to meet the demands of controlled traffic farming. T9 scraper tractors use the same Tri-Point chassis. No costly modifications are needed.



STRENGTH MEETS FLEXIBLE DESIGN

All models can be equipped with a CAT IV–N quick-hitch rear linkage, convertible to CAT III on standard frame models. Lift capacity rises to over 9071kg on standard frame tractors, in line with the high power output of the T9.560. A 20 spline 1000 speed PTO option is also available.

DRAWBAR OPTIONS

A heat-treated two position agricultural solid bar is fitted to standard frame models. A heavy duty Class 5 is offered on wide chassis models. For scraper models, a quick-hitch drawbar is Standard. Load capacities can be in excess of 4983kg on all T9 tractors, dependent on drawbar choice.



T9: BUILT SCRAPER READY

T9 tractors can be factory specified to meet the demands of scraper operators. Choices include heavy duty axles and a purpose developed drawbar. With combined high capacity and MegaFlow™ pump options, hydraulic output can reach 428 Litres per minute.

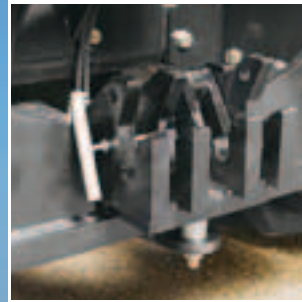

THE RIGHT BALANCE

It takes experience to ballast an articulated tractor correctly. Get the weights wrong, and performance, fuel use, soil compaction and productivity can all suffer. At New Holland we have established ballast guidelines that make it easier to optimise ballast, with purpose developed weight packs that can be tailored to match your needs.



EASY HITTING

A plug-in handheld control for the rear linkage makes hitching up attachments from ground level even easier.

IMPRESSIVE HYDRAULIC FLOW

T9 tractors are available with a standard or high flow pumps. These offer respective capacities of up to 159Lpm and 216Lpm. For demanding hydraulic applications, an optional MegaFlow™ pump is available which delivers an extra 212Lpm of hydraulic flow to one bank of remotes. For those who require the ultimate in hydraulic flow, the MegaFlow™ II option is available, this ensures that total hydraulic flow is available to all remotes. A large coupler is available for applications that demand unrestricted oil flow.



HEADLAND TURN SEQUENCE

Headland Turn Sequence (HTS) has been refined and developed by New Holland to ensure ease of use and set-up. For complex applications, including operating the very widest tillage equipment, HTS really can reduce operator fatigue. Of equal importance, the operator can use HTS to manage some operations but leave others to manual control. The choice is theirs. Set up is simply a case of recording the desired operations at the headland. The actions can then be repeated, automatically, by pressing the dedicated button on the CommandGrip™ handle.

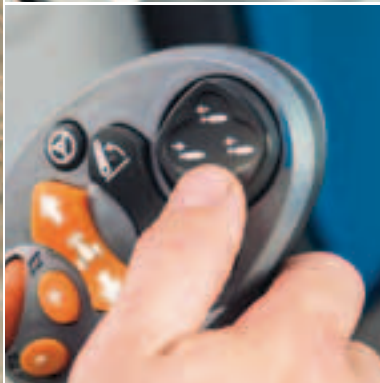

UP TO EIGHT ELECTRONIC REMOTES

T9 remote valves are easy to identify with color-coded couplers and levers. All eight remotes can be controlled without moving away from the SideWinder™ II armrest, allowing you to identify and work each remote with exact precision. Four remote levers are on the armrest and two valves are controlled either using the two additional paddles located to the right of the IntelliView™ monitor, by using the CommandGrip™ handle or by using the electronic joystick. Flow, timing and detent settings can be set to precisely match the job. Each valve can also be programmed with the Headland Turn Sequencing (HTS).

FLOW CONTROL USING THE INTELLIVIEW

The IntelliView™ touchscreen makes setting flow rates to individual valves simplicity itself. Scroll through the menus and select valve control. Choose the outlet you wish to adjust, and drag the slider with your finger to the desired setting. Job done.

360°:T9

The new T9 range has been designed to spend more time working and less time in the yard. All service points are easy to access, and super long service intervals mean they will spend more time in the field.



A dedicated hatch provides fast and easy access to the engine air filter. There is no need to lift the engine hood.

Single piece engine hood opens wide for full service access.

Steps make it easier to clean the expansive glazing of the four pillar cab.

Cooling package opens out to make cleaning faster and easier.

Tool boxes are conveniently mounted on both sides of the tractor for easy access and storage.

The 159 litre AdBlue® additive tank has a lock which prevents filling with fuel. It only needs to be filled at the same time as the 1162 litre fuel tank.



Engine and hydraulic oil check and fill points are easy to reach making routine checks fast and servicing simpler. Engine service intervals have been extended by 100% to 600 hours.



AdBlue®

DEALER INSTALLED ACCESSORIES

A comprehensive range of approved accessories to optimise machine performance in all conditions can be supplied and fitted by your dealer.



WILL I BE ABLE TO FIND ADBLUE® EASILY?
The answer is yes! It will be available on your doorstep, through CNH Industrial Parts & Service; just contact your local dealer for more information. If that wasn't enough, AdBlue can even be delivered direct to your farm for absolute convenience.



FINANCE TAILORED TO YOUR BUSINESS

CNH Industrial Capital, the financial services company of New Holland, is well established and respected within the agricultural sector. Advice and finance packages tailored to your specific needs are available. With CNH Industrial Capital, you have the peace of mind that comes from dealing with a financing company that specialises in agriculture.

TRAINED TO GIVE YOU THE BEST SUPPORT

Your dedicated New Holland dealer technicians receive regular training updates. These are carried out both through on-line courses as well as intensive classroom sessions. This advanced approach ensures your dealer will always have the skills needed to look after the latest and most advanced New Holland products.

SERVICE PLUS - LONG LASTING CONFIDENCE

Service Plus coverage from Covéa Fleet provides owners of New Holland agricultural machinery with additional cover on the expiry of the manufacturer's contractual warranty. Please ask your dealer for more details.

Terms and conditions apply.

NEW HOLLAND APPS

iBrochure

NH Weather

NH News

Farm Genius

PLM Calculator

PLM Academy



Experience New Holland
What's App!

Scan here to download the Apps



NEW HOLLAND STYLE

Want to make New Holland a part of your everyday life? Browse the comprehensive selection on www.newhollandstyle.com. A whole range of items are available including hard wearing work clothing and a vast selection of scale models, together with so much more. New Holland. As individual as you.



MODELS		T9.435	T9.480	T9.530	T9.565	T9.600	T9.645	T9.700
Engine*		FPT Cursor 9	FPT Cursor 13	FPT Cursor 13	FPT Cursor 13	FPT Cursor 13 Two-stage Turbo	FPT Cursor 13 Two-stage Turbo	FPT Cursor 13 Two-stage Turbo
No. of cylinders / Aspiration / Valves		6 / WT / 4	6 / WT / 4	6 / WT / 4	6 / WT / 4	6 / WT / 4	6 / WT / 4	6 / WT / 4
Compliant with engine emissions regulations		Tier 4B / Stage 4	Tier 4B / Stage 4	Tier 4B / Stage 4	Tier 4B / Stage 4	Tier 4B / Stage 4	Tier 4B / Stage 4	Tier 4B / Stage 4
ECObLue™ HI-eSCR system (Selective Catalytic Reduction)		●	●	●	●	●	●	●
Approved biodiesel blend**		B7	B7	B7	B7	B7	B7	B7
Bore and Stroke (mm)		117x135	135x150	135x150	135x150	135x150	135x150	135x150
Capacity (cm ³)		8700	12900	12900	12900	12900	12900	12900
Max. EPM horsepower - ISO TR14396 - ECE R120 [kW/hp(CV)]		320/435	345/469	386/525	410/557	451/613	476/647	509/692
Max. horsepower - ISO TR14396 - ECE R120 [kW/hp(CV)]		302/411	345/469	386/525	410/557	451/613	476/647	509/692
Rated EPM horsepower - ISO TR14396 - ECE R120 [kW/hp(CV)]		304/413	343/466	380/517	403/548	440/598	463/629	492/669
Rated horsepower - ISO TR14396 - ECE R120 [kW/hp(CV)]		276/375	313/426	350/476	373/507	399/542	433/589	462/628
Rated engine speed (rpm)		2000	2100	2100	2100	2100	2100	2100
Max. torque - ISO TR14396 (Nm @ rpm)		1845 @ 1400	1992 @ 1400	2229 @ 1400	2374 @ 1400	2540 @ 1400	2757 @ 1400	2941 @ 1400
Torque rise (%)		40	40	40	40	40	40	40
Viscous coupled cooling fan		●	●	●	●	–	–	–
Hydraulically driven cooling Fan		–	–	–	–	●	●	●
Earth friendly engine oil filter		●	●	●	●	●	●	●
Automatic exhaust brake		○	○	○	○	○	○	○
Diesel capacity (Litres)		829	1162	1162	1162	1162	1722	1722
DEF/AdBlue® tank capacity (Litres)		159	159	159	159	250	250	250
Service interval (hours)		600	600	600	600	600	600	600
Transmission								
IntelliShift™ system		●	●	●	●	●	●	●
Ground Speed Management system (GSM)		●	●	●	●	●	●	●
16 x 2 Ultra Command™ Full-Powershift (40kph)		●	●	●	●	●	●	●
Road Hi - Lo in 16 th gear		●	●	●	●	●	●	●
Min. speed (kph)		4	4	4	4	4	4	4
Electrical								
12 volt alternator (Amps)		200	200	200	200	240	240	240
Battery capacity (CCA)		2x1000	2x1000	2x1000	2x1000	2x1000	2x1000	2x1000
Axles								
4WD front axle		●	●	●	●	●	●	●
Articulation angle (°)		42	42	42	42	38	38	38
Turning radius (mm)		4900	4900	4900	4900	5700	5700	5700
Front & Rear Diff-lock		●	●	●	●	●	●	●
Hydraulics								
Closed Centre Load Sensing (CCLS)		●	●	●	●	●	●	●
Main pump flow Standard / High flow option (Lpm)		151 / 208	159 / 216	159 / 216	159 / 216	159 / 216	159 / 216	159 / 216
MegaFlow™ option pump flow Standard / High flow (Flow Split between left and right remotes) (Lpm)		351 / 408	371 / 428	371 / 428	371 / 428	371 / 428	371 / 428	371 / 428
MegaFlow™ II option pump flow Standard / High flow (Total flow available across all remotes) (Lpm)		351 / 408	371 / 428	371 / 428	371 / 428	371 / 428	371 / 428	371 / 428
Electronic Draft Control (EDC)		●	●	●	●	●	●	●
Remote valves								
Type		Electro hydraulic	Electro hydraulic	Electro hydraulic	Electro hydraulic	Electro hydraulic	Electro hydraulic	Electro hydraulic
Max. no. rear valves		8	8	8	8	8	8	8
Joystick control		○	○	○	○	○	○	○
Rear Linkage		○	○	○	○	○	○	○
Rear linkage category		IV-N / III	IV-N / III	IV-N / III	IV-N / III	IV-N	IV-N	IV-N
Max. lift capacity through the range (610mm behind ball ends) (kg)		9071	9071	9071	9071	8900	8900	8900
Rear PTO		○	○	○	○	○	○	○
Auto Soft Start		●	●	●	●	●	●	●
Engine speed at 1000rpm (rpm)		1800	1800	1800	1800	1800	1800	1800
Brakes								
Automatic exhaust brake		○	○	○	○	○	○	○
Electronic park brake		●	●	●	●	●	●	●
Hydraulic trailer brakes		○	○	○	○	○	○	○

MODELS	T9.435	T9.480	T9.530	T9.565	T9.600	T9.645	T9.700
Cab							
360° 4 pillar cab with FOPS - OECD Code 10 Level 1	●	●	●	●	●	●	●
Cab category level - EN 15695	2	2	2	2	2	2	2
High visibility RHS window	●	●	●	●	●	●	●
HID lighting pack	○	○	○	○	○	○	○
Auto Comfort™ seat with seat belt	●	●	●	●	●	●	●
Auto Comfort™ leather seat with seat belt	○	○	○	○	○	○	○
Instructors seat with seat belt	○	○	○	○	○	○	○
Luxury Pack (Leather Steering wheel and carpet)	○	○	○	○	○	○	○
SideWinder™ II armrest	●	●	●	●	●	●	●
CommandGrip™ handle	●	●	●	●	●	●	●
Electronic adjustment of SideWinder™ II armrest	●	●	●	●	●	●	●
Air conditioning	●	●	●	●	●	●	●
Automatic climate control	●	●	●	●	●	●	●
Air recirculation filters	●	●	●	●	●	●	●
MP3 Radio with weather channel	○	○	○	○	○	○	○
Telescopic mirrors	○	○	○	○	○	○	○
Electronic remotely adjustable mirrors	○	○	○	○	○	○	○
Comfort Ride™ cab suspension	○	○	○	○	○	○	○
Headland Turn Sequencing (HTS)	●	●	●	●	●	●	●
Remote control for rear linkage	○	○	○	○	○	○	○
A pillar Performance Monitor with enhanced key pad	●	●	●	●	●	●	●
IntelliView™ IV colour monitor with ISO 11783 connector	●	●	●	●	●	●	●
Dual IntelliView™ IV colour monitor with ISO 11783 connector	○	○	○	○	○	○	○
IntelliSteer® guidance ready	○	○	○	○	○	○	○
PLM® Connect Telematics	○	○	○	○	○	○	○
Optimum cab noise level EC 77/311 (dB(A))	76	80	80	80	76	76	76
Factory fit rotating beacons (1 / 2)	○	○	○	○	○	○	○
Weights							
Min. unballasted / shipping weights (no rear linkage or PTO fitted) (kg)	14951	15042	15626	16895	18068	20134	20134
Max. permissible weight (kg)	19051	22453	22453	22453	25401	25401	25401

● Standard ○ Optional – Not available * Developed by FPT Industrial

** Biodiesel blend must fully comply with the latest fuel specification EN14214:2009 and operation is in accordance with operator manual guidelines

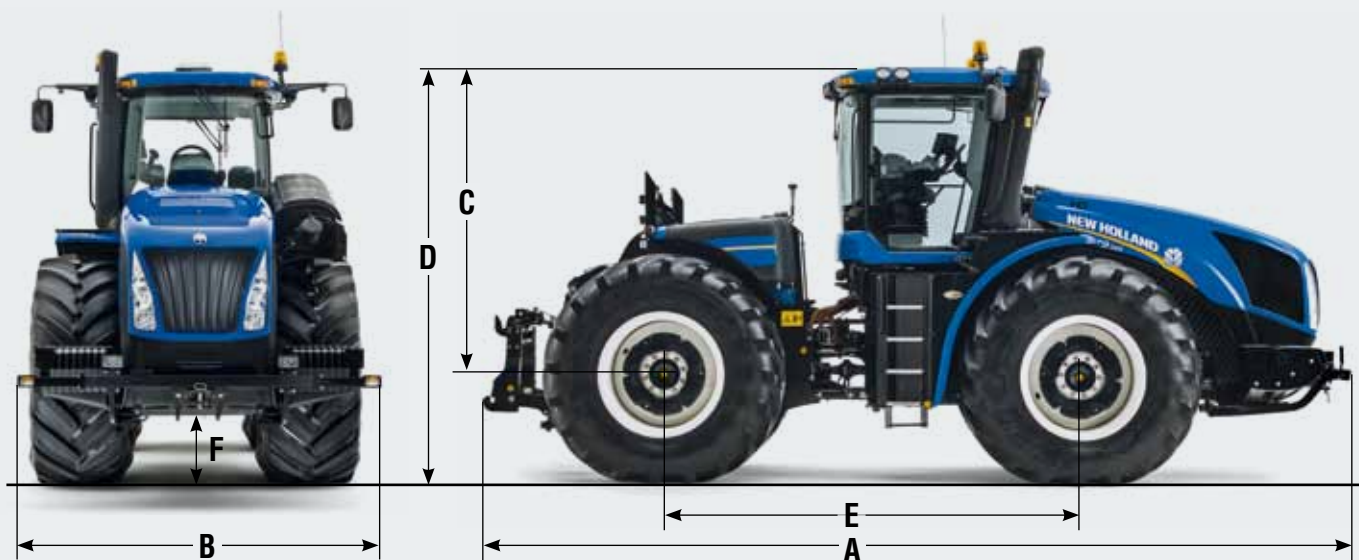

MODELS

T9.435 - T9.565

T9.600 - T9.700

Dimensions		T9.435 - T9.565	T9.600 - T9.700
With rear tyre size***		710/70R42 - Singles	710/70R42 - Singles
A Overall length inc. front weight pack and rear drawbar (mm)		7393	7615
B Min. width across bar axle (mm)		3048	3048
C Height at centre of rear axle to top of cab (mm)		2794	2903
D Overall height (mm)		3843	3963
E Wheelbase (mm)		3759	3911
F Ground clearance (depends on drawbar) (mm)		443	447

*** Rear tyres other than those mentioned are available: 380/90R54, 480/80R42, 480/80R46, 480/80R50, 480/95R50, 520/85R42, 520/85R46, 620/70R42, 620/70R46, 650/85R38, 710/70R38, 710/70R42, 800/70R38, 900/60R42

NEW HOLLAND TOP SERVICE: CUSTOMER SUPPORT AND CUSTOMER INFORMATION

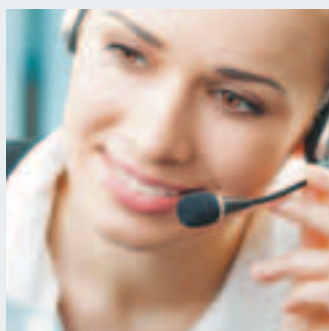

TOP AVAILABILITY

If you need information, or have an out of hours question, ring our toll-free number*. All day, every day, we are just a call away.

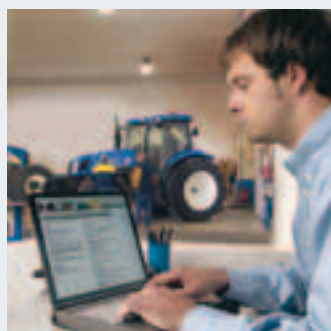

TOP SPEED

Express parts delivery: when you need it, where you need it!



TOP PRIORITY

Fast-track solution during the season: because your harvest can't wait!

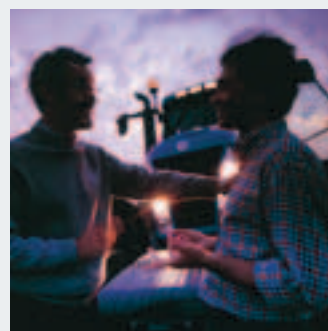

TOP SATISFACTION

We drive and track the solution you need, keeping you informed: until you are 100% satisfied!



For more details, ask your New Holland dealer!

* Calls to the Top Service team are free from landlines in the United Kingdom and Republic of Ireland. UK-based mobile calls are also free, but Republic of Ireland mobile users should call **01 2421881** and this will be charged at your standard network rate.

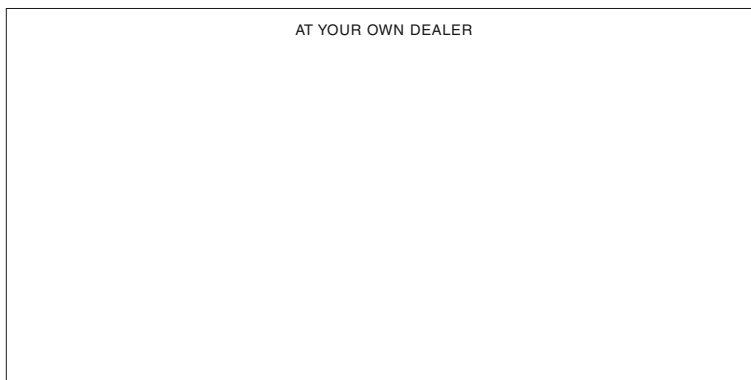

www.newholland.com/uk - www.newholland.com/ie

The data indicated in this folder are approximate. The models described here can be subjected to modifications without any notice by the manufacturer. The drawings and photos may refer to equipment that is either optional or intended for other countries. Please apply to our Sales Network for any further information. Published by New Holland Brand Communications. Bts Adv. - Printed in Italy - 03/15 - TP01 - (Turin) - 150004/INB

New Holland with

