

1. Side brush
2. Side brush mounting
3. Frontal and lateral protection
4. Lifting frame
5. Steering wheel
6. Rear mirror
7. Cabin
8. Water tank
9. Suction fan
10. Litter hopper
11. Hopper lid
12. Fuel tank
13. Rear axle
14. Wheel motor
15. Hydraulic oil tank
16. Steering axle
17. Disc brake
18. Wheel assembly
19. Suction nozzle

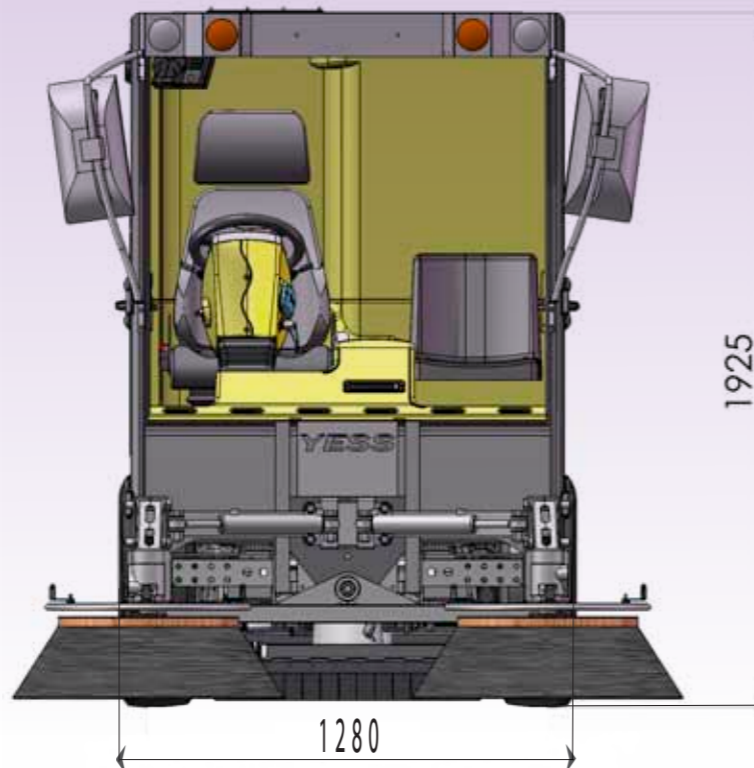

BRODD YESS®



BRODD group



BRODD SWEDEN AB
 Sjöгатan 27 Telephone
 SE-591 30 MOTALA +46 141 20 89 00 info@broddsweden.com www.broddsweden.com

YESS® 2.0E/2016C



High performance compact sweeper equipped with the most fashioned technics.

For city cleaning and maintenance of sidewalks, streets, underground car parks and industrial areas for use all year round.

Flexible, compact, silent and heavy-duty construction with simple and comfortable arrangement of all operational elements.

Easy availability for service and maintenance of the sweeper.

BRODD YESS[®]

The compact suction sweeper



Sweeping unit

The sweeping unit is ideally protected against frontal or lateral collision by the vertical lifting system and brushes spring suspension. The brushes are hydraulically driven, individually swivel mounted and each of them can be moved independently. The sweeping width is step-less adjustable 1.400 - 2.400 mm.

The vertical lifting system does not need subsequent readjustment when brushes are worn out.



Suction system

The suction nozzle is 700 mm wide and runs on rollers.

The frontal sweeping unit with the gross flap, which is actuated from the cab, picks up every type of dirt ranging from the finest sand to large stones also including dry and wet leaves, paper, bottles, crushed stones etc.

The radial heavy duty fan is subject to engine rpm up to 3.600 rpm and it works very silent. PM10 Certified.



Maneuverable

The YESS can cope with every situation, even narrow side walks, low underground car parks, steeply-inclined streets and large pedestrian areas. Thanks to the compact dimensions, the small turning radius and huge hill-climbing ability, it can do the work quickly and thoroughly.



Cab

The comfort cab with its adjustable and aircushioned health-conductive driver's seat, the ergonomically arranged operating elements, competent sound proofing, effective heating and air fan or airconditioning unit (option) meets all requirements for a healthy and comfortable working climate, all year round.



Everything in view

The additional mirror in the front allows the driver to have a constant view of the dirt intake through the suction nozzle.



Dumping

The lifting and tilting device makes it possible to empty into any large capacity container.



Dirt container

The stainless steel dirt container can be filled almost up to 100% thanks to the special developed air filter and air rerouting system. The high degree of compacting optimises the degree of filling even further.



Water system

The water system stores 280 l in the fresh water tank and up to 150 l in the water re-cycling system. The system takes up the used water again and use it for the additional dust binding in the suction mouth. The cylindrical dirt water filter in the dirt container ensures maximum recycling of the used water.



Engine

The YESS is driven by a sturdy 70 kW water cooled 4-cylinder diesel engine.

Emission levels according to Euro 5 (ECE 88/77 norm).



Hand held suction hose (option)