

PG >>>



**Gianni
Ferrari**





PG

Gianni Ferrari PG is a multi-purpose machine for the maintenance of green areas and open spaces.

Specializing in cutting and collecting grass... great in many other applications!



Public green areas

In parks and public green areas you can often find litter, dirt and grass clippings, but the combined action of the collection deck and the effective suction turbine cleans and collects perfectly. This is why PG machines are particularly useful in the maintenance of playgrounds, school courtyards, campsites and in all those situations where cleanliness and safety are essential for the enjoyment of green areas. With a powerful collection system cleaning is ensured and the appearance is impeccable. In addition, PG proves extremely effective in the collection of leaf litter.



Sports clubs

PG is a machine very much appreciated by sports clubs. In fact, in addition to equipment for the maintenance of natural grass (mower, aerator / dethatcher, sand spreader), specific equipment is also available for the maintenance of synthetic turf as well as for cleaning athletic tracks. One machine and lots of equipment for a real team play!

Municipal maintenance

Its natural habitat are parks and gardens, but thanks to the more compact size of its class, PG even moves easily and effectively in city traffic, including roundabouts, pavements and traffic islands, where it can also be used as a sweeper or equipped for snow removal. In addition, the PG diesel versions have achieved approval as self-propelled machines for road use. These characteristics make them particularly suitable for municipal maintenance, even in winter. A machine for all seasons.





**Gianni
Ferrari**



> Transmission

The front axle consists of a differential assembly that connects two reduction gears in oil baths, which transmit the drive to the wheels. The transmission system is very efficient as the hydraulic axial piston motor ensures high performance.

In difficult conditions (uneven ground, slopes or poor grip) the mechanical differential with 100% lock ensures that all the available axle torque is transmitted to the wheel offering better grip, always ensuring excellent traction. The 4WD models adopt the unique HTC™ (Hydrostatic Traction Control) device, which provides significant advantages, including:

- preventing the steering wheels damaging the turf when steering, by eliminating the slippage caused by the dragging effect;
- ensuring permanent 4-wheel drive to benefit the safety of the operator. This is very important considering that, when turning, some solutions in the market disengage the traction on one or two wheels, thus losing the prerogative of the 4WD at the expense of safety.

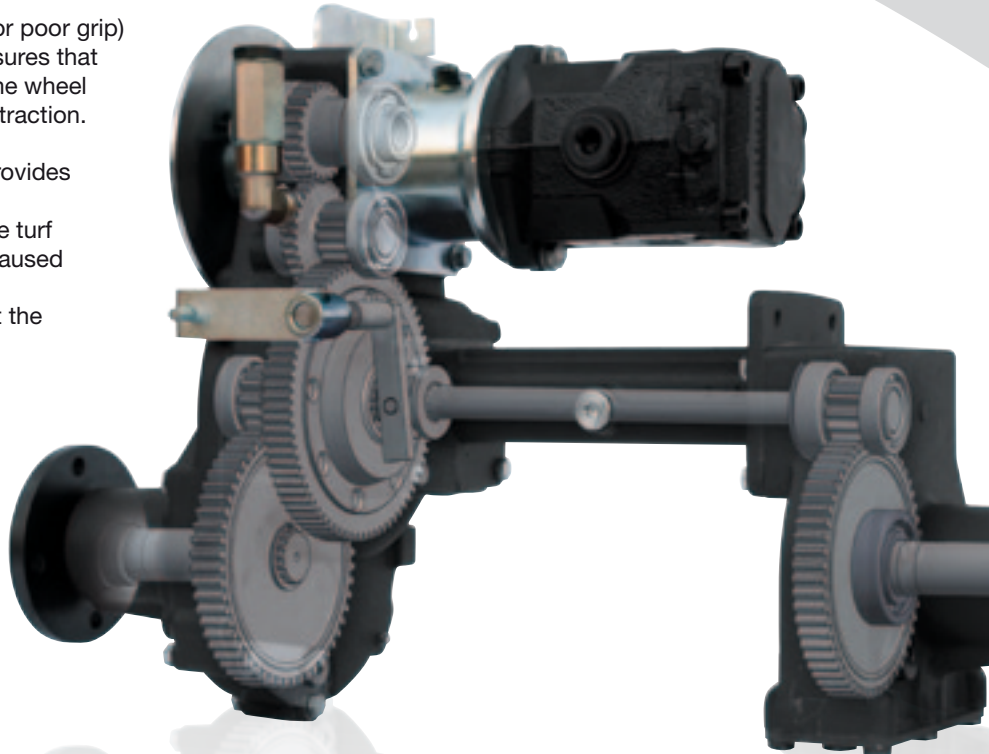

> Engines

The PG range is equipped with professional, low emission petrol and diesel engines that satisfy the current anti-pollution directives. The two-cylinder petrol engines are equipped with a dual element air filter and pressure lubrication system with oil filter.

These features increase the protection and durability of the engine. For maximum performance 3-cylinder diesel engines with liquid cooling are available. The combined water / oil radiator with anti-clogging fin is of generous size and ensures a high thermal exchange even in tough conditions, to benefit the longevity of the engine, oil and hydraulic components. The filter system with self-cleaning cyclonic pre-filter protects the engine and extends its life.



**Gianni
Ferrari**



> Eco-Drive™

The diesel models are equipped with an Eco-Drive™ selector for more efficient and comfortable use. In Eco-Drive mode, engine, power take-off and collection turbine run at reduced speed for good fuel economy and low noise level. In tougher working situations the Boost mode can be selected, where engine, power take-off and collection turbine run at full revs.

▶ Steering

The power steering acts on the rear wheels, ensuring precision and swiftness, reducing operator fatigue and working time. A version is available with rear twin-wheel for an extremely tight turning radius and easy handling. The 4 wheel version has an oscillating rear axle, enabling a tight turning radius, as well as stability and safety when crossing slopes.



▶ Driving Position

The driver's seat is designed to be easy on the operator even after many hours of work. The steering column tilts, the steering wheel is ergonomically designed with soft grip and knob. A single pedal quickly and intuitively controls forward and reverse for ease of use. To adapt to the size and weight of each operator the seat is adjustable in depth and the seat springing is adjustable for height and stiffness. All controls are easily accessible and the hydraulic distributor levers are protected against accidental operation. In the diesel models a display provides information on the machine (hour meter, engine coolant temperature, fuel level, etc.) and diagnostics for the safety systems and system faults.

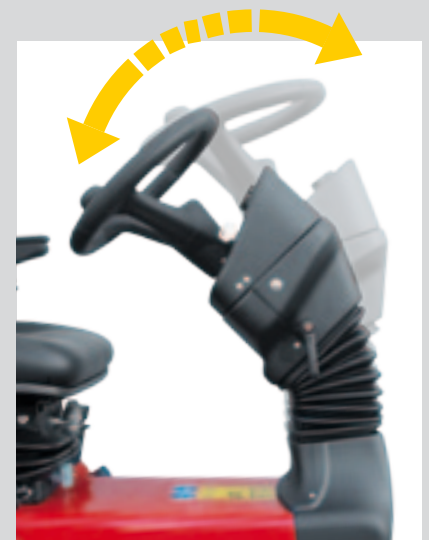



FRONT DECK

➤ **Better cutting quality as grass is not compacted before being cut**

➤ **Better visibility and comfort for the operator**

➤ **Better manoeuvrability and cut in areas that cannot be reached by mid-mounted decks**

➤ **Better terrain following and superior finish, a thing that mid-mounted decks cannot achieve**

➤ **Easier access for deck maintenance**



➤ Integrated collection system

PG front mowers are designed for cutting and collecting grass simultaneously. This basic concept provides the machine with an integrated loading system: the suction turbine and the collection hose are housed inside the traction unit, with many advantages:

- no bulky external collection hoses, keeping the machine compact. The mower is easy to manoeuvre and can be used in tight spaces and thus increase productivity. With no outer hose obstructions the machine is free to work on both sides to further benefit productivity;
- compared to competitors with outer collection hoses, this machine is more stable and balanced, having a better-placed centre of gravity;
- collection is more effective because the cut grass has to travel a shorter distance, hence no friction losses. In this way no cutting waste is left on the lawn and this also prevents clogging the turbine and collecting duct;
- the machine is versatile because the turbine and hopper are always available for use with various equipment.

➤ Collector

The large 800 litre collector is made from sturdy impact-resistant material and is fitted with a filter, deflector and warning buzzer to indicate when the hopper is full. The filter is easily removable for cleaning. The buzzer advises the operator to disengage the PTO when the hopper is full, to prevent clogging the collecting duct. An impact-resistant perimeter frame in tubular steel protects the collector and fairings from knocks that frequently occur when working in confined spaces or close to obstacles.





▶ **Soft cab**

A cab enclosure kit is available to turn the ROPS with roof into a soft cab. The soft cab offers good protection from the elements and maintains the ROPS safety feature. The kit consists of doors and rear transparent PVC sheet, with a Plexiglas windshield and manual wiper. A heated seat is available as an option.

▶ **ROPS with roof**

In place of the foldable ROPS it is possible to install a fixed protective structure complete with roof. The ROPS protects the driver, should the machine overturn and the canopy provides shelter from sun and rain and protects the operator from branches when working under trees.



▶ **Cab**

A hard cab with tempered approved glass windows is available for 4WD models. Ventilation system with dust filter and heating. Doors with external locks and assisted opening mechanism with gas springs. Hinged opening windscreen with electric windscreen wiper. Headlights and rear-view mirrors for road use. Rear work lights. Interior courtesy lights. The cab is mounted on silent blocks and can be tipped forward to allow maintenance access to the engine and transmission. Easily removable doors. A heated seat is available as an option.

▶ **High-lift dump**

4 wheel PG models can also be fitted with a lifting device. A parallelogram system with hydraulic drive allows the collector to be lifted up to 1.90 metres and emptied directly into the dump body of a truck or trailer. Emptying is also possible at any height lower than maximum, using the independent dumping control.



126SA



130RCA

Collection decks

The mower decks are floating so as to adapt naturally to the undulations in the ground for a more accurate cut. The deck wheels are puncture-proof with full soft rubber tyres.

The mowers are equipped with disks with dual pairs of shockproof swing back blades. This system offers three main advantages:

- the swing back blades absorb shocks and protect the transmission against impact with foreign objects left in the grass;
- the dual blades prevent the accumulation of grass and soil debris in the top inside part of the mower deck, maintaining cut quality uniform throughout the session, and reducing downtime for cleaning the deck;
- the cut material is reduced to very small particles, improving collection and compaction in the collection hopper.

Model	112	126SA	130RCA
Cutting width	112 cm	126 cm	130 cm
Blades	2 discs with dual pairs of shock-absorbing swing back blades		
Blade rotation	counter-rotating (standard)		reverse rotation RC™
Cutting height adjustment	with height-adjusting pins, 2 cm to 8 cm	quick adjustment with SA™ lever, 2 cm to 8 cm	
Mulching	optional kit		mulching plug supplied as standard

In full compliance with safety standards, an opening has been made in front of the shell of models 126SA and 130RCA to make the edge higher than the level of the cutting blade. This difference in height avoids flattening the grass and allows the blade to make an accurate cut even when the grass is tall. The deck maintains appropriate safety using mobile flaps that open in the presence of tall grass and close with short grass or if struck by objects coming from inside.

The 130RCA mower stands out for the direction of blade rotation, contrary to that of conventional mowers. The RC™ reverse rotation, combined with the unique, specifically designed shape of the deck shell, offers a cutting quality close to that obtainable with a cylinder blade mower and also a very high production rate.



Transmission

The spheroidal graphite cast iron gearboxes, with spiral bevel gears in oil bath, are sturdy and reliable. The discs with shockproof swing back blades protect the transmission against impact with foreign objects left in the grass.



Hydraulic lift

This enables the machines to mount kerbs and pavements up to 17 cm high! The maintenance mode easily allows the inspection, cleaning and maintenance of the lower part of the mower (only for 126SA and 130RCA, with 23" wheels).

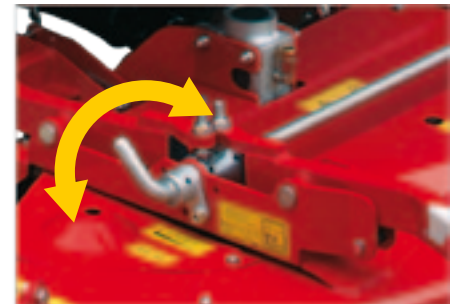

Quick adjustment SA™

All mowers (except model 112) are equipped with the exclusive Single Action SA™, quick adjust system, which allows the cutting height to be adjusted in less than 10 seconds by simply moving a lever.



Rear discharge deck

Mower with 3 blades. Single Action SA™ quick adjust cutting height. Very sturdy and productive even on tall grass. Cutting width 130 cm.



Mulching and side discharge deck

Mower with belt drive and 3 blades. Prepared in the mulching version and convertible to side discharge with the conversion kit supplied as standard. Single Action SA™ quick adjust cutting height. Cutting width 150 cm.



Flail mower

Especially suitable for cutting long grass, clearing country areas and shredding brushwood. Centralised cutting height adjustment.

Y or, on request, paddle flails.

Available with working widths of 110 or 135 cm.



Aerator / dethatcher

Particularly useful in spring and in late summer to remove thatch, weeds and moss in order to help the grass "breathe" or for preparing the area for overseeding.

Working width 100 cm.

Optional vacuum kit for collecting debris.





Snow blade

For removing snow from roads, car parks, drives and pavements. Horizontally pivoted to adapt to the terrain and hydraulic angling $\pm 30^\circ$ on both sides.

Replaceable cutting edge. Working width 130 cm.



Snow thrower

Two-stage snow thrower for the removal of large amounts of snow. Hydraulic rotation of the ejection pipe and manually adjustable deflector chute angle. \varnothing 40 cm auger with icebreaking teeth. Intake height 65 cm. Adjustable and replaceable lower steel cutting edge, adjustable skid shoes. Working width 130 cm. For use of the snow thrower without cab a Plexiglas windscreen is available as an optional which protects the operator.



Rotary broom

For cleaning roads, pavements and industrial surfaces. Horizontally pivoted to adapt to the terrain and hydraulic angling $\pm 30^\circ$ on both sides. The rotary broom is equipped with a valve for the hydraulic regulation of the rotation speed and support wheels to adjust the working height. Roller diameter 45 cm and working width 140 cm.



Spreader

Can spread salt, sand, grit, fertilizer and granulates of various types, weights and sizes. The spreading width can be varied on the control panel while driving, from 0.8 m (pavements) up to 6 m (roads, car parks). Constructed in rustproof materials: the distributor and spreading plate in stainless steel and the hopper in polyethylene.

A special hinged mounting system provides access to the hopper where can be stored the material to be spread (sacks of salt, sand, etc.). Capacity 110 litres.



Leaf vacuum hose

The 5 metre suction hose is ideal for collecting large amounts of leaves, paper, plastic bottles and cans, reaching areas which are inaccessible to the machine. The hose is fitted with a stainless steel end nozzle. An optional filtering net can be fitted inside the collector.



Two-stage collection sweeper and water sprayer kit

The sweeper is equipped with two front-mounted steel/polypropylene brushes and two internal brushes. The anti-dust filter is fitted inside the collector and a water spraying kit is available to moisten the road surface and reduce the amount of dust raised by the rotating brushes: 40 litre water tank. Working width 120 cm.



Sweeper for artificial turfs with infill

For routine maintenance of artificial grass fields with rubber granules and/or sand infill. The sweeper removes dust, leaves, broken artificial grass fibres, etc.

Thanks to the vibrating sieve, the dirt is collected in the machine hopper, while the sand and granules are returned on the surfaces.

The action of the sweeper straightens the fibres and levels the playing surface, it moves and tills the infill material and prevents the growth of moss and weeds. This helps maintain the permeability and elasticity of the playing surface.

Various types of sieves are available for different types of infill. The sweeper comes with an anti-dust filter as standard. Working width 100 cm.



Sweeper for unfilled artificial grass

This sweeper can be used for the brushing and cleaning of artificial grass without infill. Also suitable for cleaning athletic fields and tracks in tartan.

The sweeper straightens the fibers and removes dirt (dust, leaves, broken artificial grass fibres, etc.) which is then collected in the machine hopper.

The sweeper is fitted with a lateral brush which can be operated independently and useful for working near edges or awkward areas.

The sweeper comes with an anti-dust filter as standard. Working width 100 cm.

TECHNICAL SPECIFICATIONS



GTM - GSM
15,5-16 hp



GTR
16-20 hp



GTS
22-23 hp



GT
28 hp



TURBO Z
23 hp



TURBOGRASS
22-23 hp



PG - SR
22-28 hp



TURBO 1-1W-2-4
28-44 hp



TURBOLOADER
22-36 hp

Model	PG 230	PG 220 D	PG 280 D	PG 280 DW
Engine				
Fuel Model	Petrol Vanguard V-Twin 386400	Diesel Kubota D902	Diesel Kubota D1105	Diesel Kubota D1105
Power / Displacement	23 hp / 627 cc.	22 hp / 898 cc.	28 hp / 1123 cc.	28 hp / 1123 cc.
No. Cylinders / Cooling	2 / Air	3 / Liquid	3 / Liquid	3 / Liquid
Fittings	Pressure lubrication system with gear pump – fuel filter with prefilter – cyclone-type air filter with self cleaning prefilter			
Fuel tank capacity	30 L	30 L	30 L	30 L
Eco-Drive™ mode	–	●	●	●
Hydrostatic transmission				
Driving wheels	2WD	2WD	2WD	Permanent 4WD
Transmission type	Combined motor/pump unit coupled with front gear drive axle. Deep reduction front axle			Variable displacement axial piston pump. Axial piston motor on front gear drive axle and orbital motors on rear wheels. Deep reduction front axle
Max forward speed	11 km/h	11 km/h	11 km/h	13 km/h
Traction control		Mechanical differential lock		HTC™ system – mechanical differential lock
Forward/reverse motion	Single forward/reverse foot pedal			
Brakes	Hydrostatic service brake (neutral position). Disc parking brake on front axle			
Steering system	Power steering wheel, reduced-radius steering on rear wheels			
Wheels/Tyres				
20" Front wheels (20 x 10.00 - 8)	●	●	–	–
- Rear twin-wheel (version)	15 x 6.00 - 6	15 x 6.00 - 6	–	–
- Rear oscillating axle (version)	15 x 6.00 - 6	15 x 6.00 - 6	–	–
23" Front wheels (23 x 10.50 - 12)	●	●	●	●
- Rear twin-wheel (version)	15 x 6.00 - 6	15 x 6.00 - 6	–	–
- Rear oscillating axle (version)	16 x 7.50 - 8	16 x 7.50 - 8	16 x 7.50 - 8	16 x 7.50 - 8
Power Take-Off				
Type / Engagement		Mechanical, with cardan shaft / Engagement by hand lever		
Auxiliary hydraulics	Optional	Twin double-acting quick-release couplings		
Front linkage				
Type	Hydraulic with 2 arms			
Collecting system				
Type	Built-in turbine-assisted collection			
Collector	High impact resistant polyethylene, with anti-clogging audible buzzer of full load. Removable filtering screen for cleaning			
Collector capacity	800 L	800 L	800 L	800 L
Emptying height / Dumping system	79 cm / Hydraulic	79 cm / Hydraulic	81 cm / Hydraulic	80 cm / Hydraulic
High-lift dump (available for units with rear oscillating axle only)				
Minimum emptying height	190 cm	190 cm	192 cm	196 cm
Overhang at maximum height	35 cm	35 cm	35 cm	30 cm
Driver's seat				
Steering wheel	Soft-touch steering wheel with knob and tilt adjustable steering column			
Seat	Contour-molded seat with high backrest		Comfort seat with armrests	
	Optional comfort seat with armrests, heated seat also available		Seat heating (optional)	
Seat suspension	Parallelogram suspension with adjustable height position and driver's weight adjustment			
Cab				
Soft cab (optional)	●	●	●	●
Hard cab (optional)	–	–	–	●
Electrical system				
Battery	12 V / 44 Ah – battery master switch as standard			
Safety sensors	EEC European Standard / ISO			
Warning system	Engine oil pressure – fuel reserve – battery – parking brake – coolant temperature (diesel versions only)			
Standard equipment	ECU for diagnostic on safety systems and fault sensing (diesel versions only) – hour meter – front work lights			
Weight and measures (tractor unit only, basic version)				
Unloaded weight ¹	550 kg	650 kg	700 kg	800 kg
Length / Width / Height ¹	225 x 106 x 164 cm	225 x 106 x 164 cm	227 x 114 x 166 cm	227 x 114 x 170 cm

¹ without ROPS

The availability of models, versions and trim may vary depending on the country.

